



TURBINE GAS METER



METER



1	Design and function	page 2
2	General technical data	page 3
3	Measurement outputs	page 4
4	Dimensions and weights	page 5
5	Performance	page 7
6	Pressure loss	page 8
7	Installation and operation recommendations	page 8



CGT series turbine gas meters are flow meters designed to measure quantity of gases. The meters are mainly used for gas flow ranges from 6.5 up to 6500 m³/h. The CGT series gas meters are applied in measurement systems where high accuracy is required:

- transportation of natural gas
- primary and secondary measurements
- control metering of the natural gas and non aggressive technical gases in industry
- flow measurement for technical purposes

The meters may be applied for measurements of aggressive gases. Any application of that kind should be individually proved and agreed between the client and COMMON S.A.

1 DESIGN AND FUNCTION

The turbine gas meter measures the quantity of gas basing on the flow principle. The gas flows through an integrated flow conditioner, which distributes the flow proportionally in the annular slot and guides it to the turbine wheel. The wheel is driven by the gas flow, and the angular velocity of the rotation is proportional to the gas flow rate. The energy consumption, perceived as pressure loss, is reduced to absolute feasible minimum due to

the application of the flow conditioner, highest precision ball bearings, most accurate tolerances of all measuring parts and their proper alignment. The rotary motion of the turbine wheel is transferred mechanically by gear wheels, and the incorporated gas tight and hermetic magnetic coupling, to the index unit, which is mounted on the top of the body, and shows the operating volume on the totalizer.

The basic components of the COMMON CGT series turbine gas meter are as follows:

- pressure resistant meter body
- inlet flow conditioner
- measuring cartridge with the turbine wheel
- magnetic coupling as the transferring element between measuring cartridge and the index
- index
- lubricating system (some meters are provided with self lubricating bearings)

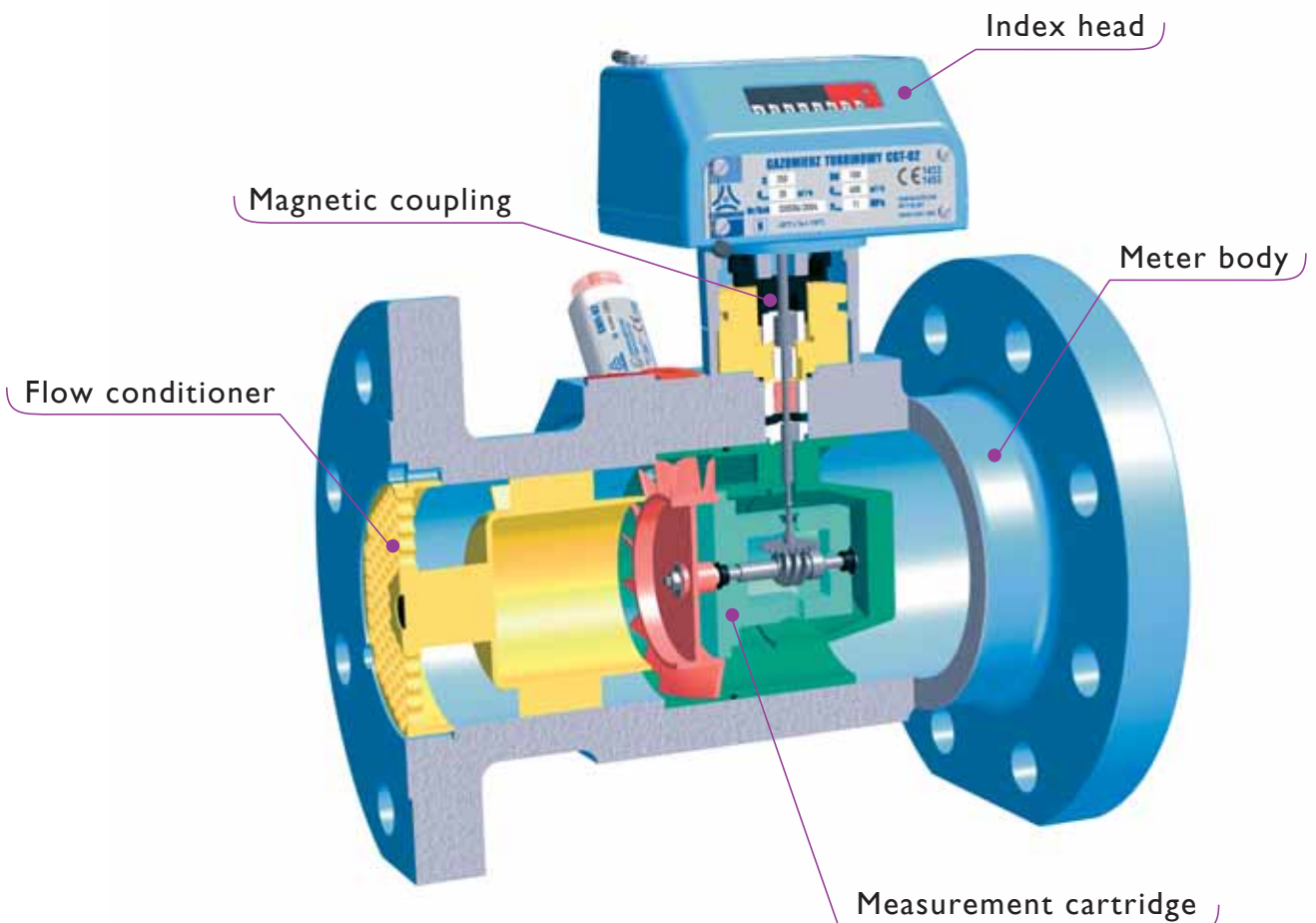

table 1

DN		G	Maximum flow Q_{min} [m ³ /h]	Minimum flow Q_{min} [m ³ /h]	LF pulse rate U_a [m ³ /pulse]
mm	inch				
50	2	40	65	6	0,1
		65	100	10	
80	3	100	160	8	1
		160	250	13	
		250	400	20	
100	4	160	250	13	1
		250	400	20	
		400	650	32	
150	6	400	650	32	1
		650	1000	50	
		1000	1600	80	
200	8	650	1000	50	1
		1000	1600	80	
		1600	2500	130	
250	10	1000	1600	80	10
		1600	2500	130	
		2500	4000	200	
300	12	1600	2500	130	10
		2500	4000	200	
		4000	6500	320	

- pressure rating: PN16 to PN110, ANSI150 to ANSI600 other rates on request
- nominal diameter: DN50 up to DN300 standard range, other on request
- meter bodies: cast iron or carbon steel details in table 4
- flow: 6.5 to 6 500 m³/h other on request
- rangeability: 1:20 minimum at atmospheric pressure
Some smaller size meters have reduced ranges.
- upstream pipe: minimum 2 x DN;
meters meet the requirements of the OIML R32 89 Annex A
- temperature range: gas temperature -20°C to +60°C
ambient temperature -25°C to +70°C
- allowed medias: see table 2
- operating position: horizontal or vertical

measurement accuracy: EU requirements and better
 guaranteed at least: $0.2 Q_{\max} - Q_{\max} < \pm 1\%$
 $Q_{\min} - 0.2 Q_{\max} < \pm 2\%$

fig.2: Measurement error typical curve

- at low pressure (average 1 bara) green curve
- at high pressure (over 5 bara) blue curve

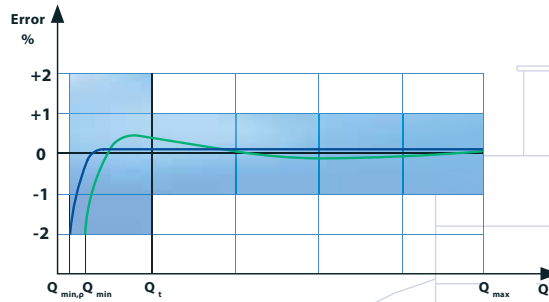

Gas	Chemical symbol (formula)	Density ρ [kg/m ³]	Density related to air	Gas meter execution
Argon	Ar	1,66	1,38	standard IIB
Butane	C ₄ H ₁₀	2,53	2,10	standard IIB
Carbon dioxide	CO ₂	1,84	1,53	standard IIB
Carbon monoxide	CO	1,16	0,97	standard IIB
Ethane	C ₂ H ₆	1,27	1,06	standard IIB
Ethylene	C ₂ H ₄	1,17	0,98	standard IIB
Helium	He	0,17	0,14	standard IIB
Methane	CH ₄	0,67	0,55	standard IIB
Natural gas	-	~0,75	~0,63	standard IIB
Nitrogen	N ₂	1,16	0,97	standard IIB
Propane	C ₃ H ₈	1,87	1,56	standard IIB
Acetylene	C ₂ H ₂	1,09	0,91	special IIC
Hydrogen	H ₂	0,084	0,07	special IIC
Air	-	1,20	1,00	standard IIB

table 2: Physical properties of most popular gases that may be measured with the CGT turbine gas meters - density at 101,325 kPa and at 20°C

3 MEASUREMENT OUTPUTS

PRESSURE AND TEMPERATURE OUTPUTS

The operating pressure (reference pressure) can be taken from the pressure taps, marked pr, located on both sides of the meter body.

The meters DNI00 and larger can be optionally equipped with two temperature taps for the measurement of the gas temperature.

PULSE SENSORS

The mechanical index unit indicates the actual volume of the measured gas at operating temperature and operating pressure. It can be rotated axially by 350° in order to facilitate the readings and enable easier connection of pulse sensor plugs.

The index unit is provided with one low frequency LFK reed contact pulse transmitter, as a standard. On request the index may be equipped with:

- LFI inductive pulse sensor (NAMUR)
- HF inductive pulse sensor (NAMUR)

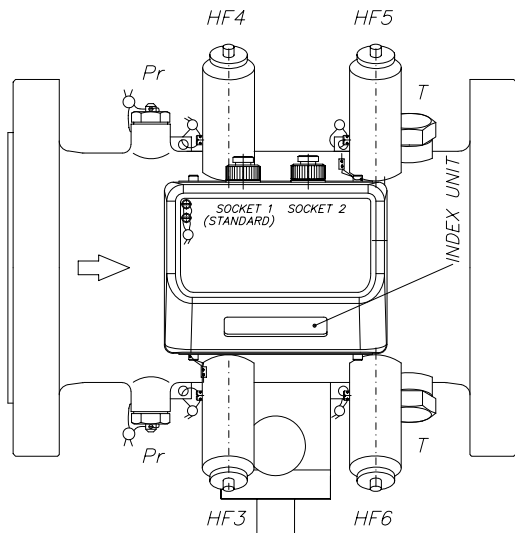

fig. 2. Location of measurement outputs (top view)

HF	LFI	LFK, AFK
U _i = 16 V Dc	U _i = 15,5 V DC	U _i = 15,5 V DC
i _i = 25 mA	i _i = 52 mA	i _i = 52 mA
P _i = 64 mW	P _i = 169 mW	P _i = 169 mW
L _i = 50 μH	L _i ≈ 40 μH	L _i ≈ 0
C _i = 30 nF	C _i = 28 nF	C _i ≈ 0

table 3: Permissible supply parameters of intrinsically safe circuits.

The CGT turbine gas meters may be provided with up to 10 pulse sensors for DN100 – DN300 and up to 8 pulse sensors for DN50 – DN80

- LFK – low frequency reed contact pulse sensor LFK1, LFK2
- LFI – low frequency inductive pulse sensor LFI1, LFI2
- HF – inductive pulse sensor in the index unit HF1, HF2
- HF – inductive pulse sensor over the turbine wheel HF3, HF4
- HF – inductive pulse sensor over the reference wheel HF5, HF6
- AFK – anti-fraud reed contact AFK

The turbine wheel, as a standard, is made of aluminium. This allows to provide each CGT turbine gas meters with HF inductive pulse sensors. There are no extra costs due to the replacement of the turbine wheel.

fig. 3 Pulse sensor pin numbering in sockets 1 and 2 installed in the index

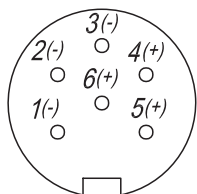

Pin No	Socket 1 pulse sensors	Socket 2 pulse sensors
1 - 4	LFK 1 (standard)	LFK 2
2 - 5	LFI 1	LFI 2
3 - 6	HF 1 or AFK	HF 2

The sockets match the TUCHEL plug No C09I 3IH006 I00 2

fig. 4 Pulse sensor pin numbering in socket of the HF pulse transmitter installed in the meter body

Pin No	HF over turbine wheel		HF over reference wheel	
	HF 3	HF 4	HF 5	HF 6
3 - 4				

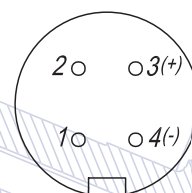

The sockets match the TUCHEL plug No C09I 3ID004 I00 2

DIMENSIONS AND WEIGHTS

Overall dimensions and weights of CGT turbine gas meters are shown in Table 4

fig.5 Dimensions of the CGT turbine gas meter

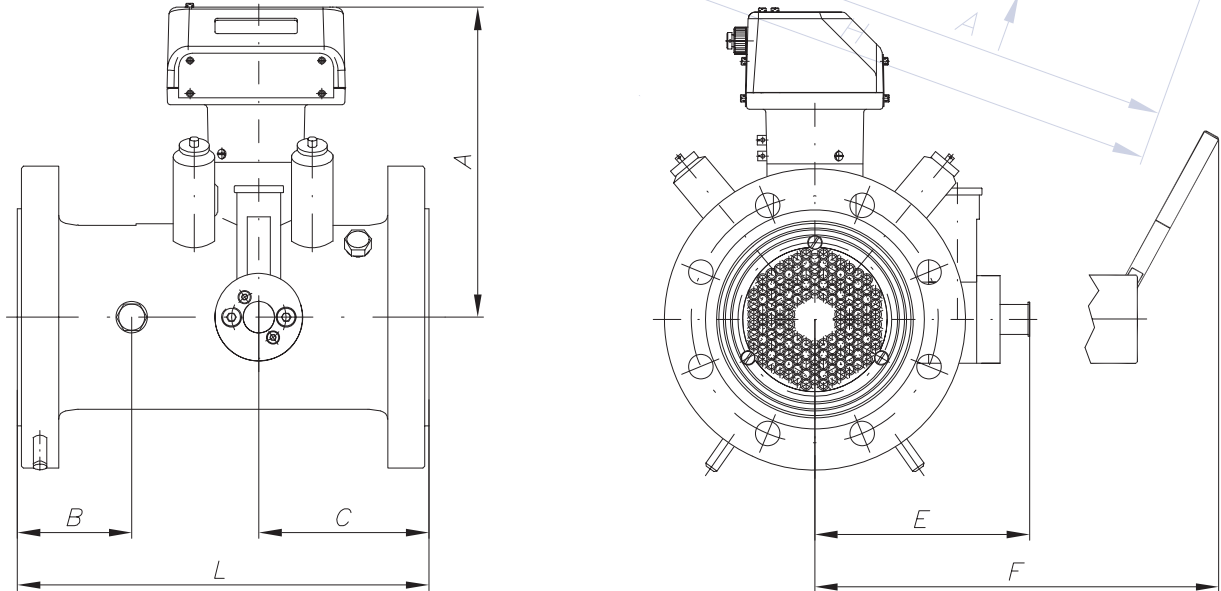

table 4

DN		L	A	B	C	E, F*	Flange		Weight	
mm	inch						ANSI	PN	cost iron	steel
		mm	mm	mm	mm	mm	-	-	kg	kg
50	2	150	203	42	58	150	-	16	8,5	11
							150	20	9,5	10
							300	50	-	11,5
80	3	240	206	60	95	146	-	64	-	14
				80			110	-	14	
				-			16	20	25	
100	4	300	220	101	124	157	-	20	19,5	24,5
							150	50	-	27,5
							300	64	-	28
150	6	450	247	125	180	185	-	110	-	32
				155			16	25	33,5	
				-			20	26,5	34,4	
200	8	600	270	212	240	202	-	50	-	43
							150	64	-	40
							300	110	-	56
250	10	750	298	270	330	232	-	16	48	62,5
							150	20	47	62,5
							300	50	-	80,5
300	12	900	323	300	350	258	-	64	-	84
							150	110	-	106
							300	16	-	80
300	12	900	323	300	350	345	-	20	-	86
							150	50	-	116
							300	64	-	128
300	12	900	323	300	350	345	-	110	-	153
							150	16	-	142
							300	20	-	147
300	12	900	323	300	350	345	-	50	-	190
							150	64	-	206
							300	110	-	271
300	12	900	323	300	350	345	-	16	-	215
							150	20	-	235
							300	50	-	290
300	12	900	323	300	350	345	-	64	-	300
							150	110	-	360
							300	16	-	-

* size E is valid for meters PN16, PN20 and ANSI 150, size F is valid for meters PN50, PN64, PNI 10, ANSI300 and ANSI600

5 PERFORMANCE

The meter measures the actual quantity of gas flowing at operating conditions (pressure and temperature). This volume is displayed on the index as actual volume in m³. The most important factor of the meter size selection (nominal diameter) is the expected minimum and maximum gas flow at the operating conditions.

According to standards the turndown ratio is determined at atmospheric conditions (p = 1.01325 bar).

DEFINITION:

- Q_{min m} = minimum flow at operating conditions [m³/h]
- Q_{min} = minimum flow of the meter at atmospheric conditions [m³/h]
- p = gauge pressure [bar]

In order to convert parameters from base to operating conditions, and vice versa, the following formula may be applied:

$$V_m = V_s \cdot k \cdot \frac{p_s}{p_m} \cdot \frac{T_m}{T_s} \approx V_s \cdot Z \cdot \frac{(t_m + 273)}{273 \cdot (p + 1)}$$

DEFINITION:

- V_m = volume at operating conditions [m³/h]
- V_s = volume at base conditions [m³/h]
- k = relative compressibility factor
k = Z / Z_n
- Z = real gas factor at operating conditions
- Z_s = real gas factor at base conditions
- p_s = base pressure (1.01325 bar)
- p_m = operating pressure (abs.) at the turbine meter [bar]
- p = operating gauge pressure at the turbine meter [bar]
- T_s = base gas temperature [K] (273.15K)
- T_m = operating gas temperature [K]
- t_m = operating gas temperature [°C]

The measurement range increases with the increase of operating pressure. Q_{min} value decreases, and it may be calculated from the following formula:

$$Q_{min m} = Q_{min} \cdot \sqrt{\rho_a / \rho_m} \quad [m^3/h]$$

The operating density ρ_m may to be determined as follows:

$$\rho_m \approx (p + 1) \cdot \rho \quad [kg/m^3]$$

- ρ = standard density of the gas [kg/m³] see table 2 (for natural gas: 0.75 kg/m³)
- ρ_a = standard density of air [kg/m³] (1.2 kg/m³)

6 PRESSURE LOSS

The inevitable pressure loss during the gas flow through the meter is determined at the atmospheric conditions.

To determine pressure losses at other, higher pressures, the following formula applies:

$$\Delta p_1 = \left(\frac{\rho}{\rho_a} \right) \cdot \left(\frac{p+p_s}{p_s} \right) \cdot \Delta p$$

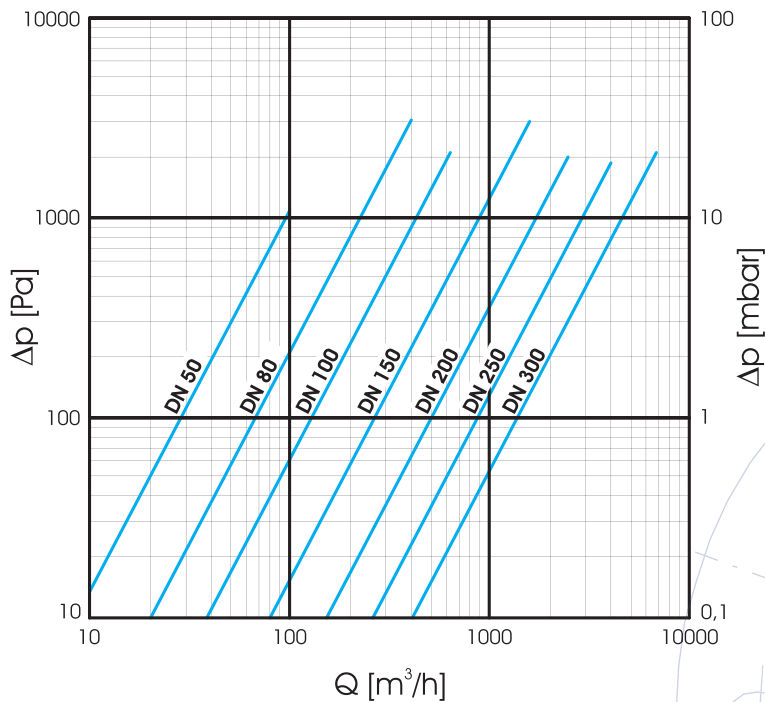

fig. 6 Diagram of pressure loss related to $\rho = 1,2 \text{ kg/m}^3$

DEFINITION:

- Δp_1 = pressure loss at p
- Δp = pressure loss from the diagram, fig. 6
- p = gauge pressure [bar]
- ρ = standard density of gas [kg/m^3]
- ρ_a = standard density of air $1,2 \text{ kg/m}^3$
- p_s = base pressure (1.01325 bar)

7 INSTALLATION AND OPERATION RECOMMENDATIONS

- Meters should be shipped in their original package to the place of installation.
- Meters have to be handled with care and protected against falls, direct influence of rain, snow or high humidity.
- The measured gas should be clean, dry and free from solid impurities. It is recommended that the upstream pipe installation is to be equipped with a filter (10 micron).
- Prior to putting into operation in new installations, it is recommended to install a temporary cone sieve.
- Prior to installation the upstream and downstream pipe flanges should be aligned properly.
- Flange gaskets are to be installed so as not to disturb the gas flow.

- The gas flow should be in accordance with the arrow placed on the meter body.
- The piping should be executed so as to avoid unnecessary stresses acting on the meter.
- When used outdoors the meter should be protected against direct weather influence.
- When starting the gas flow through the installation, the valves should be opened slowly to ensure a gradual increase of pressure.

ATTENTION! If valves are opened abruptly or pressure increase takes place in a short time it may happen that the measurement cartridge or the turbine wheel get damaged.

**ALWAYS REMEMBER TO START UP THE METERS
IN A PROPER WAY!**



COMMON S.A. has continuing program of product research and development. Technical specifications and construction may change due to improvements. This publication serves as general information only, and all specifications are subject to confirmation by COMMON S.A.

TURBINE GAS METER

• YOUR PARTNER

TURBINE GAS METER

TURBINE GAS METER



COMMON S.A.

ul. Aleksandrowska 67/93

91-205 Łódź, Poland

tel. + 48 42 253 66 57

+ 48 42 253 66 58

fax + 48 42 253 66 99

<http://www.common.pl>

e-mail: common@common.pl